

# HEAVY DUTY DOUBLE SPRING SIGN STAND FOR ALUMINUM SIGNS

Mount aluminum signs 84" above ground!

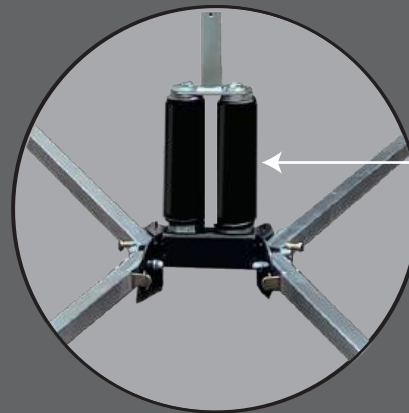

Model SS621A



Heavy Duty  
Double Spring with  
Wind Sleeves™

**MASH  
APPROVED**



- Holds rigid signs 36" & 48"
- Wind Sleeves™ increase stand stability with aluminum signs
  - patent pending
- Automotive grade steel, double spring
  - designed to perform in extreme weather conditions without fatiguing or breaking
  - E-coated for maximum rust and corrosion resistance
- Telescoping mast
- Fixed length legs
  - lock in multiple positions to adjust to uneven ground
- Non-skid rubber feet
- Built-in three flag holder
- Replacement parts and assemblies available
- MASH Accepted for 48" - .080 aluminum signs, WZ-427
  - mount aluminum signs at 84" from the ground
- Meets MUTCD Standards

## Zinc Plated Universal Brackets

Rigid brackets for top and bottom of the sign have different clamp sizes to fit around telescoping mast.



Bracket for Rigid Sign

**PLASTICADE®**

Plasticade.com

TF064 Rev. 3

# HEAVY DUTY DOUBLE SPRING SIGN STAND FOR ALUMINUM SIGNS

## .080 Aluminum Sign Mounting

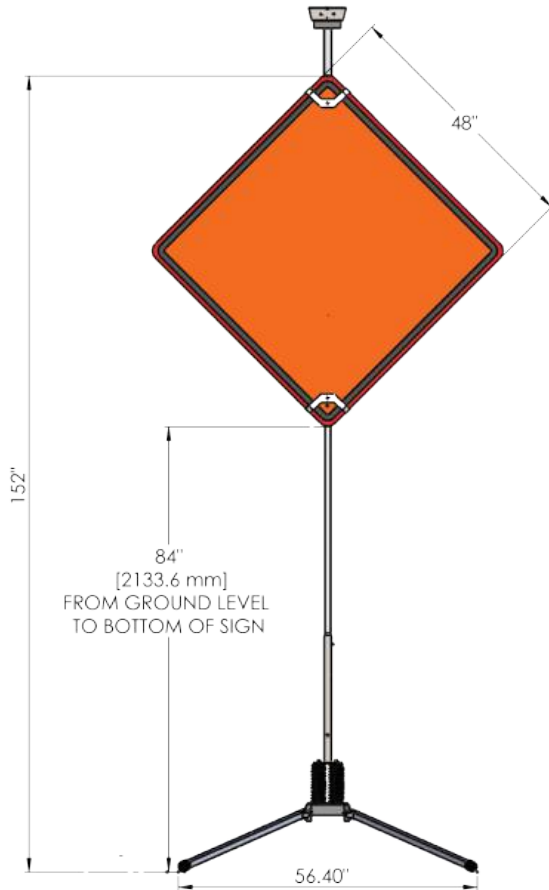

### Specs

Material	Aluminum
Model	SS621A
Sign Mounting Height	84" from ground
Top of 48" Sign	Top - 152" H maximum
Carton Size	9" x 12" x 72"
Size Open legs collapsed footprint	legs don't collapse
Size Open legs fully extended footprint	56.4" x 130.6"
Brackets for rigid sign	Top: SH-HSL-95 Bottom: SH-HSHL-96
Weight	56 lbs.

Rigid Sign Bracket - U.S. Patent 10,546,515  
other patents pending

## LEG RELEASE SYSTEM

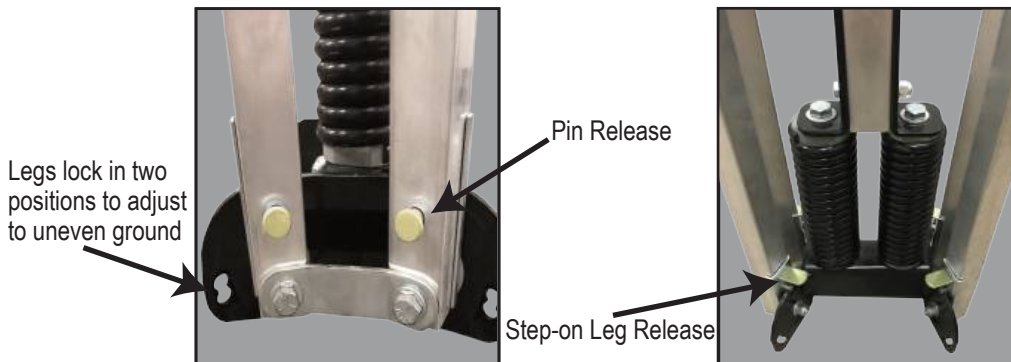

**PLASTICADE®**

100 Howard Avenue  
Des Plaines, IL 60018  
phone (800) 772-0355  
info@plasticade.com  
[Plasticade.com](http://Plasticade.com)