



U.S. Department
of Transportation
**Federal Highway
Administration**

May 29, 2020

1200 New Jersey Ave., SE
Washington, D.C. 20590

In Reply Refer To:
HSST-1/WZ-408

Mr. Henry A. Ross
Plasticade
100 Howard Avenue
Des Plaines, IL 60018
USA

Dear Mr. Ross:

This letter is in response to your February 24, 2020 request for the Federal Highway Administration (FHWA) to review a roadside safety device, hardware, or system for eligibility for reimbursement under the Federal-aid highway program. This FHWA letter of eligibility is assigned FHWA control number WZ-408 and is valid until a subsequent letter is issued by FHWA that expressly references this device.

Decision

The following device is eligible within the length-of-need, with details provided in the form which is attached as an integral part of this letter:

- Plasticade® Fibercade® Type I and Type II Barricade

Scope of this Letter

To be found eligible for Federal-aid funding, new roadside safety devices should meet the crash test and evaluation criteria contained in the American Association of State Highway and Transportation Officials' (AASHTO) Manual for Assessing Safety Hardware (MASH). However, the FHWA, the Department of Transportation, and the United States Government do not regulate the manufacture of roadside safety devices. Eligibility for reimbursement under the Federal-aid highway program does not establish approval, certification or endorsement of the device for any particular purpose or use.

This letter is not a determination by the FHWA, the Department of Transportation, or the United States Government that a vehicle crash involving the device will result in any particular outcome, nor is it a guarantee of the in-service performance of this device. Proper manufacturing, installation, and maintenance are required in order for this device to function as tested.

This finding of eligibility is limited to the crashworthiness of the system and does not cover other structural features, nor conformity with the Manual on Uniform Traffic Control Devices.

Eligibility for Reimbursement

Based solely on a review of crash test results and certifications submitted by the manufacturer, and the crash test laboratory, FHWA agrees that the device described herein meets the crash test and evaluation criteria of the AASHTO's MASH. Therefore, the device is eligible for reimbursement under the Federal-aid highway program if installed under the range of tested conditions.

Name of system: Plasticade® Fibercade® Type I and Type II Barricade

Type of system: Work Zone

Test Level: MASH Test Level 3 (TL3)

Testing conducted by: Texas A&M Transportation Institute (TTI).

Date of request: February 24, 2020

FHWA concurs with the recommendation of the accredited crash testing laboratory on the attached form.

Full Description of the Eligible Device

The device and supporting documentation, including reports of the crash tests or other testing done, videos of any crash testing, and/or drawings of the device, are described in the attached form.

Notice

This eligibility letter is issued for the subject device as tested. Modifications made to the device are not covered by this letter. Any modifications to this device should be submitted to the user (i.e., state DOT) as per their requirements.

You are expected to supply potential users with sufficient information on design, installation and maintenance requirements to ensure proper performance.

You are expected to certify to potential users that the hardware furnished has the same chemistry, mechanical properties, and geometry as that submitted for review, and that it will meet the test and evaluation criteria of AASHTO's MASH.

Issuance of this letter does not convey property rights of any sort or any exclusive privilege. This letter is based on the premise that information and reports submitted by you are accurate and correct. We reserve the right to modify or revoke this letter if: (1) there are any inaccuracies in the information submitted in support of your request for this letter, (2) the qualification testing was flawed, (3) in-service performance or other information reveals safety problems, (4) the system is significantly different from the version that was crash tested, or (5) any other information indicates that the letter was issued in error or otherwise does not reflect full and complete information about the crashworthiness of the system.

Standard Provisions

- To prevent misunderstanding by others, this letter of eligibility designated as FHWA control number WZ-408 shall not be reproduced except in full. This letter and the test documentation upon which it is based are public information. All such letters and documentation may be reviewed upon request.
- This letter shall not be construed as authorization or consent by the FHWA to use, manufacture, or sell any patented system for which the applicant is not the patent holder.
- This FHWA eligibility letter is not an expression of any Agency view, position, or determination of validity, scope, or ownership of any intellectual property rights to a specific device or design. Further, this letter does not impute any distribution or licensing rights to the requester. This FHWA eligibility letter determination is made based solely on the crash-testing information submitted by the requester. The FHWA reserves the right to review and revoke an earlier eligibility determination after receipt of subsequent information related to crash testing.

Sincerely,



Michael S. Griffith
Director, Office of Safety Technologies
Office of Safety

Enclosures

Request for Federal Aid Reimbursement Eligibility of Highway Safety Hardware

Submitter	Date of Request:	February 24, 2020	<input checked="" type="radio"/> New <input type="radio"/> Resubmission
	Name:	Henry A. Ross	
	Company:	Plasticade	
	Address:	100 Howard Avenue, DesPlaines, IL 60018	
	Country:	U.S.A.	
To:	Michael S. Griffith, Director FHWA, Office of Safety Technologies		

I request the following devices be considered eligible for reimbursement under the Federal-aid highway program.

Device & Testing Criterion - Enter from right to left starting with Test Level

!-!-!

!-!-!

System Type	Submission Type	Device Name / Variant	Testing Criterion	Test Level
'WZ':Crash Worthy Work Zone Traffic Control Devices	<input checked="" type="radio"/> Physical Crash Testing <input type="radio"/> Engineering Analysis	Plasticade®Fibercade® Type I and Type II Barricade	AASHTO MASH	TL3

By submitting this request for review and evaluation by the Federal Highway Administration, I certify that the product(s) was (were) tested in conformity with the AASHTO Manual for Assessing Safety Hardware and that the evaluation results meet the appropriate evaluation criteria in the MASH.

Individual or Organization responsible for the product:

Contact Name:	Henry A. Ross	Same as Submitter <input checked="" type="checkbox"/>
Company Name:	Plasticade	Same as Submitter <input checked="" type="checkbox"/>
Address:	100 Howard Avenue, DesPlaines, IL 60018	Same as Submitter <input checked="" type="checkbox"/>
Country:	U.S.A.	Same as Submitter <input checked="" type="checkbox"/>

Enter below all disclosures of financial interests as required by the FHWA 'Federal-Aid Reimbursement Eligibility Process for Safety Hardware Devices' document.

Texas A&M Transportation Institute (TTI) was contracted by Plasticade® to perform full-scale crash testing of the Plasticade®Fibercade® Type I and Type II Barricade. There are no shared financial interests in the Plasticade®Fibercade® Type I and Type II Barricade by TTI, or between Plasticade® and TTI, other than costs involved in the actual crash tests and reports for this submission to FHWA.

690900-PLP5&6

PRODUCT DESCRIPTION

Help	<p> <input checked="" type="radio"/> New Hardware or Significant Modification <input type="radio"/> Modification to Existing Hardware </p> <p> The Fibercade® Type I and Type II barricade is 43.3 inches tall, 24 inches wide, and 41.5 inches long. The barricade is built from component parts secured with steel hardware. All components used are made from HDPE (High Density Polyethylene) plastic. The top boards were 12 inches × 24 inches × 0.6 inch thick. The bottom boards were 8 inches × 24 inches × 0.6 inch thick. A safety light (Empco-Lite Model 2006 with 4 D-cell batteries) was attached to the test article, bringing total height of the barricade to 50.8 inches to the top of the safety light. The test article weighed 18 lb (including the 3-lb safety light), and a 35-lb sand bag was placed over one lower leg. Plasticade® provided the test articles and drawings. </p> <p style="text-align: center;">CRASH TESTING</p> <p> By signature below, the Engineer affiliated with the testing laboratory, agrees in support of this submission that all of the critical and relevant crash tests for this device listed above were conducted to meet the MASH test criteria. The Engineer has determined that no other crash tests are necessary to determine the device meets the MASH criteria. </p>	
Engineer Name:	D. Lance Bullard, Jr., P.E.	
Engineer Signature:	D. Lance Bullard, Jr.	Digitally signed by D. Lance Bullard, Jr. Date: 2020.03.02 08:38:29 -06'00'
Address:	3100 SH47, Bldg 7091, Bryan, TX, 77807	Same as Submitter <input type="checkbox"/>
Country:	U.S.A.	Same as Submitter <input type="checkbox"/>

A brief description of each crash test and its result: [Help](#)

Required Test Number	Narrative Description	Evaluation Results
3-70 (1100C)	MASH states that Test 3-70 for small vehicles is considered optional for work-zone traffic control devices weighing less than 220 lb, because velocity changes during low-speed impacts with free-standing, lightweight features will be within acceptable limits. The Plasticade® Fibercade® Type I and Type II Barricade traffic control device weighed 18 lb (including the 3-lb safety light) each, exclusive of the sandbags. Therefore, MASH Test 3-70 was not performed on this traffic control device.	Non-Critical, not conducted

Required Test Number	Narrative Description	Evaluation Results
3-71 (1100C)	<p>MASH Test 3-71 involved an 1100C vehicle weighing 2420 lb ±55 lb impacting the traffic control device at an impact speed of 62 mi/h ±2.5 mi/h. Per MASH recommendations, the device was tested at critical impact angles (CIAs) of 90° ±1.5° and 0° ±1.5°.</p> <p>The results of test 690900-PLP5 conducted on October 25, 2019 and test 690900-PLP5R1 conducted on October 28, 2019 are found in TTI Test Report number 690900-PLP5&6.</p> <p>For Test PLP5, the test vehicle was traveling at an impact speed of 62.0 mi/h when it contacted the first barricade at an impact angle of 0°. During the impact with the second barrier, the vehicle struck only the far side leg of the second barricade. Due to the glancing nature of the 90° impact, the barricade could not be fully evaluated at 90°. Therefore, the test at 90° was repeated and is reported herein as Test No. 690900-PLP5R1 (described below). The first barricade fractured into numerous pieces. The debris field for the first barricade extended 30 ft downstream of impact, and 6 ft to the left and 4 ft to the right of the vehicle path. The front bumper, air dam, and hood were damaged. The hood sustained three small deformation areas and scratches. The windshield sustained cracking near the right wiper blade due to contact with the safety light, but no tearing of the laminate was observed.</p> <p>For Test PLP5R1, the test vehicle was traveling at an impact speed of 62.6 mi/h when it contacted the barricade at an impact angle of 0°. The barricade fractured into numerous pieces. The debris field for the barricade extended 4 ft to 105 ft downstream of impact, and 6 ft to the left and 14 ft to the right of the vehicle path. The front bumper and hood were damaged. The hood sustained three small deformation areas: one 4 inches × 14 inches × 0.5 inch deep, a second 4 inches × 12 inches × 0.5 inch deep, and the third 4 inches × 12 inches × 0.5 inch deep. There was no damage to the windshield. Neither occupant compartment deformation nor intrusion was observed on either test PLP5 or PLP5R1.</p> <p>For brevity, please see 3-72 next page re: device weight and occupant risk factors. The Fibercade® performed acceptably for MASH test 3-71 with impact angles of 0° and 90°.</p>	PASS

3-72 (2270P)	<p>MASH Test 3-72 involves a 2270P vehicle weighing 5000 lb \pm 110 lb impacting the traffic control device at an impact speed of 62 mi/h \pm 2.5 mi/h. Per MASH recommendations, the device was tested at critical impact angles (CIAs) of 90° \pm 1.5° and 0° \pm 1.5°.</p> <p>The results of test 690900-PLP6 conducted on October 28, 2019 are found in TTITest Report number 690900-PLP5&6. The test vehicle was traveling at an impact speed of 62.1 mi/h when it contacted the first barricade at an impact angle of 0°. The vehicle was traveling at an impact speed of 61.7 mi/h and impact angle of 90° when it contacted the second barrier. Brakes on the vehicle were applied after loss of contact with the second barricade, and the vehicle came to rest 405 ft downstream of the impact and 7 ft left of centerline of the vehicle path. The barricades fractured into numerous pieces. The debris field extended 240 ft downstream of impact with the first barricade, and 87 ft to the left and 32 ft right of the vehicle path. The front bumper, grill, and hood were damaged. The hood sustained a small indentation of 8 inches \times 7 inches \times 0.75 inch deep. There was no damage to the windshield. No occupant compartment deformation or intrusion was observed.</p> <p>MASH does not require instrumentation of the vehicle when impacting lightweight, freestanding work zone traffic control devices weighing less than 220 lb, therefore the occupant risk factors were not calculated for this test. The Plasticade® Fibercade® Type I and Type II Barricade weighed 18 lb (including the 3-lb safety light) each, exclusive of the sandbags.</p> <p>The Fibercade® performed acceptably for MASH test 3-72 with impact angles of 0° and 90°.</p>	PASS
--------------	---	------

Full Scale Crash Testing was done in compliance with MASH by the following accredited crash test laboratory (cite the laboratory's accreditation status as noted in the crash test reports.):

Laboratory Name:	TexasA&M Transportation Institute	
Laboratory Signature:	Digitally signed by Darrell L. Kuhn 'Date: 2020.02.28 17:17:50 -06'00' 	
Address:	3100SH47, Bldg 7091, Bryan, TX, 77807	SameasSubmitter <input type="checkbox"/>
Country:	U.S.A	SameasSubmitter <input type="checkbox"/>
Accreditation Certificate Number and Dates of current Accreditation period :	ISO 17025-2017 Laboratory A2LA Certificate Number: 2821.01 Valid To: April 30, 2021	

Submitter Signature*: **Henry Ross** Digitally signed by Henry Ross
Date: 2020.03.03 16:24:49
-06'00'

Submit Form

ATTACHMENTS

Attach to this form:

- 1) Additional disclosures of related financial interest as indicated above.
- 2) A copy of the full test report, video, and a Test Data Summary Sheet for each test conducted in support of this request.
- 3) A drawing or drawings of the device(s) that conform to the Task Force-13 Drawing Specifications [[Hardware Guide Drawing Standards](#)]. For proprietary products, a single isometric line drawing is usually acceptable to illustrate the product, with detailed specifications, intended use, and contact information provided on the reverse. Additional drawings (not in TF-13 format) showing details that are relevant to understanding the dimensions and performance of the device should also be submitted to facilitate our review.

FHWA Official Business Only:

Eligibility Letter		
Number	Date	Key Words

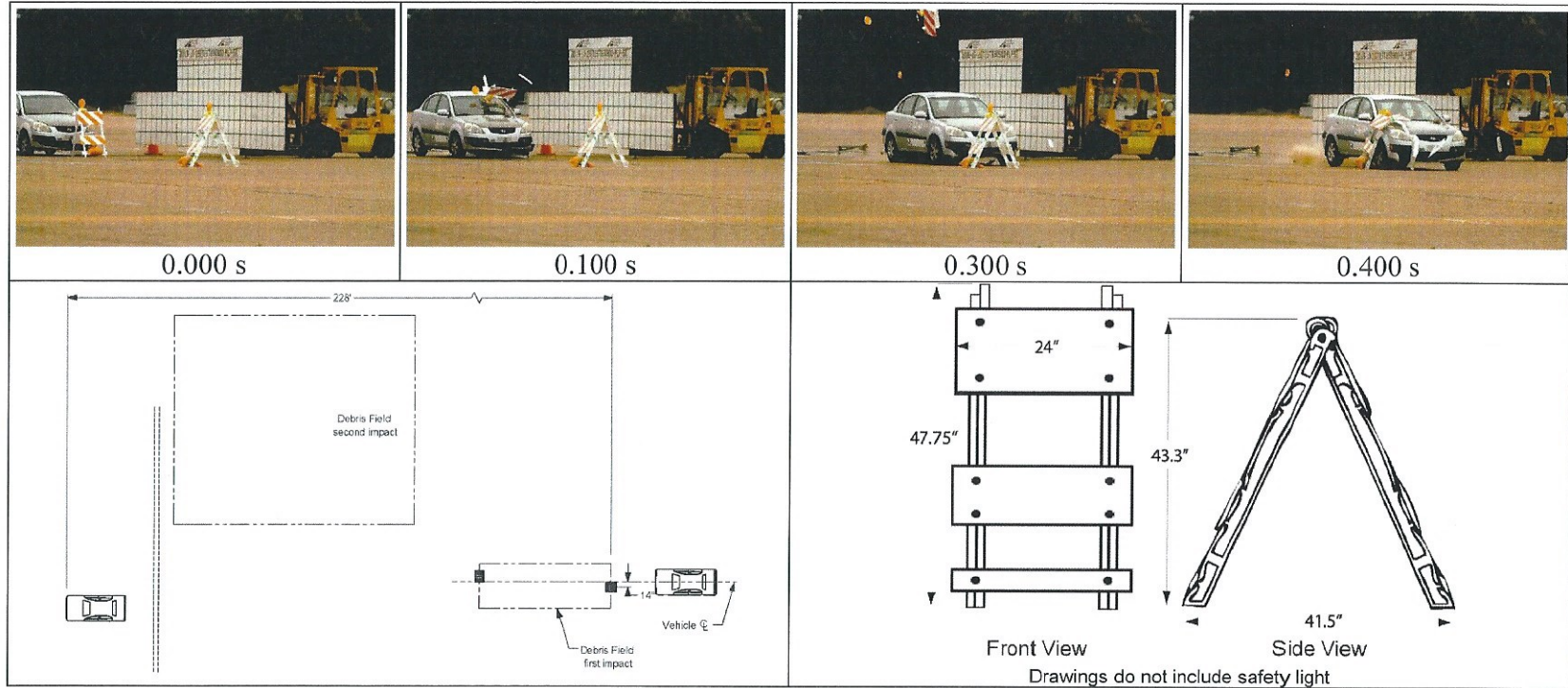

General Information

Test Agency..... Texas A&M Transportation Institute (TTI)
 Test Standard Test No..... MASH Test 3-71 at 0° and *90°
 TTI Test No. 690900-PLP5
 Test Date..... 2019-10-25
 *the 90° test was rerun

Test Article

Type Work-Zone Traffic Control Device -
 Type I and Type II Barricade
 Name..... Plasticade® Fibercade®
 Installation Height/Weight .. 50.8 inches / 18 lb (both include light)
 Material or Key Elements ... HDPE legs, HDPE boards, safety light,
 and one 35-lb sand bag

Soil Type and Condition

Concrete pavement, damp

Test Vehicle

Type/Designation..... 1100C
 Make and Model 2008 Kia Rio
 Curb 2465 lb
 Test Inertial..... 2424 lb
 Dummy 165 lb
 Gross Static 2589 lb

Impact Conditions

Speed Barricade #1 62.0 mi/h
 Angle Barricade #1..... 0°
 Speed Barricade #2..... 60.3 mi/h
 Angle Barricade #2..... 90°

Kinetic Energy #1 & #2..... 311 & 295 kip-ft

Exit Conditions

Speed Barricade #1 60.3 mi/h
 Speed Barricade #2 58.7 mi/h

Post-Impact Trajectory

Stopping Distance 228 ft downstream

Maximum Test Debris Scatter

Barricade #1 30 ft downstream
 6 ft left/4 ft right
 Barricade #2 30-70 ft downstream
 13-60 ft right

Vehicle Damage

VDS..... 12FD1
 CDC 12FDEN1
 Max. Exterior Deformation None
 OCDI FS000000
 Max. Occupant Compartment
 Deformation..... None
 Windshield Damage None

Figure 5.6. Summary of Results for MASH Test 3-71 at 0° on Plasticade® Fibercade® Type I and Type II Barricades

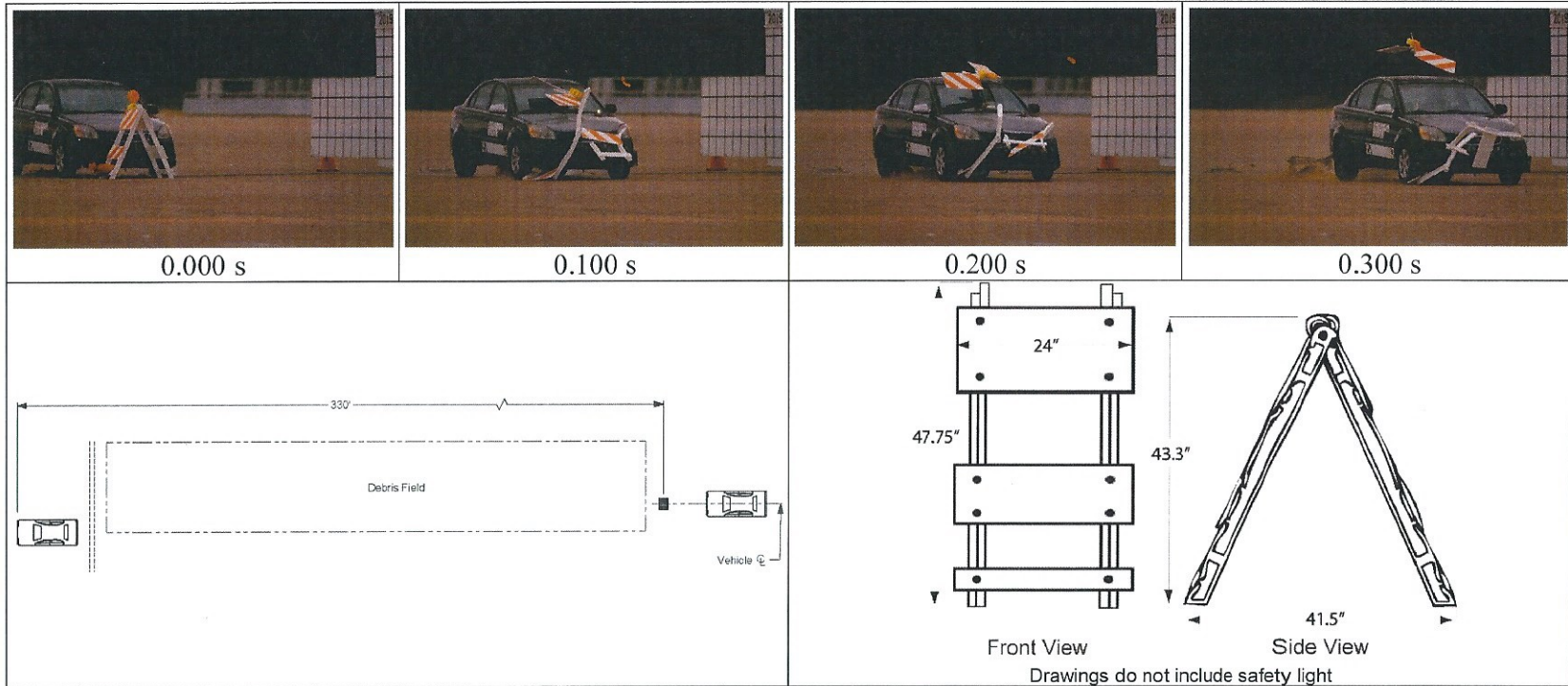

General Information

Test Agency..... Texas A&M Transportation Institute (TTI)
 Test Standard Test No..... MASH Test 3-71 Rerun at 90°
 TTI Test No. 690900-PLP5R1
 Test Date..... 2019-10-28

Test Article

Type Work-Zone Traffic Control Device -
 Type I and Type II Barricade
 Name..... Plasticade® Fibercade®
 Installation Height/Weight .. 50.8 inches / 18 lb (both include light)
 Material or Key Elements... HDPE legs, HDPE boards, safety light,
 and one 35-lb sand bag

Soil Type and Condition Concrete pavement, damp

Test Vehicle

Type/Designation 1100C
 Make and Model 2011 Kia Rio
 Curb..... 2343 lb
 Test Inertial 2441 lb
 Dummy 165 lb
 Gross Static 2606 lb

Impact Conditions

Speed Barricade #1 62.6 mi/h
 Angle Barricade #1..... 90°

Kinetic Energy 319 kip-ft

Exit Conditions

Speed Barricade #1 62.0 mi/h

Post-Impact Trajectory

Stopping Distance 330 ft downstream
 6 ft left of center

Maximum Test Debris Scatter

Barricade #1 4-105 ft downstream
 6 ft left/14 ft right

Vehicle Damage

VDS..... 12FD1
 CDC 12FDEN1
 Max. Exterior Deformation 0.5 inch
 OCDI FS0000000
 Max. Occupant Compartment
 Deformation..... None
 Windshield Damage None

Figure 6.6. Summary of Results for MASH Test 3-71 at 90° on Plasticade® Fibercade® Type I and Type II Barricade.

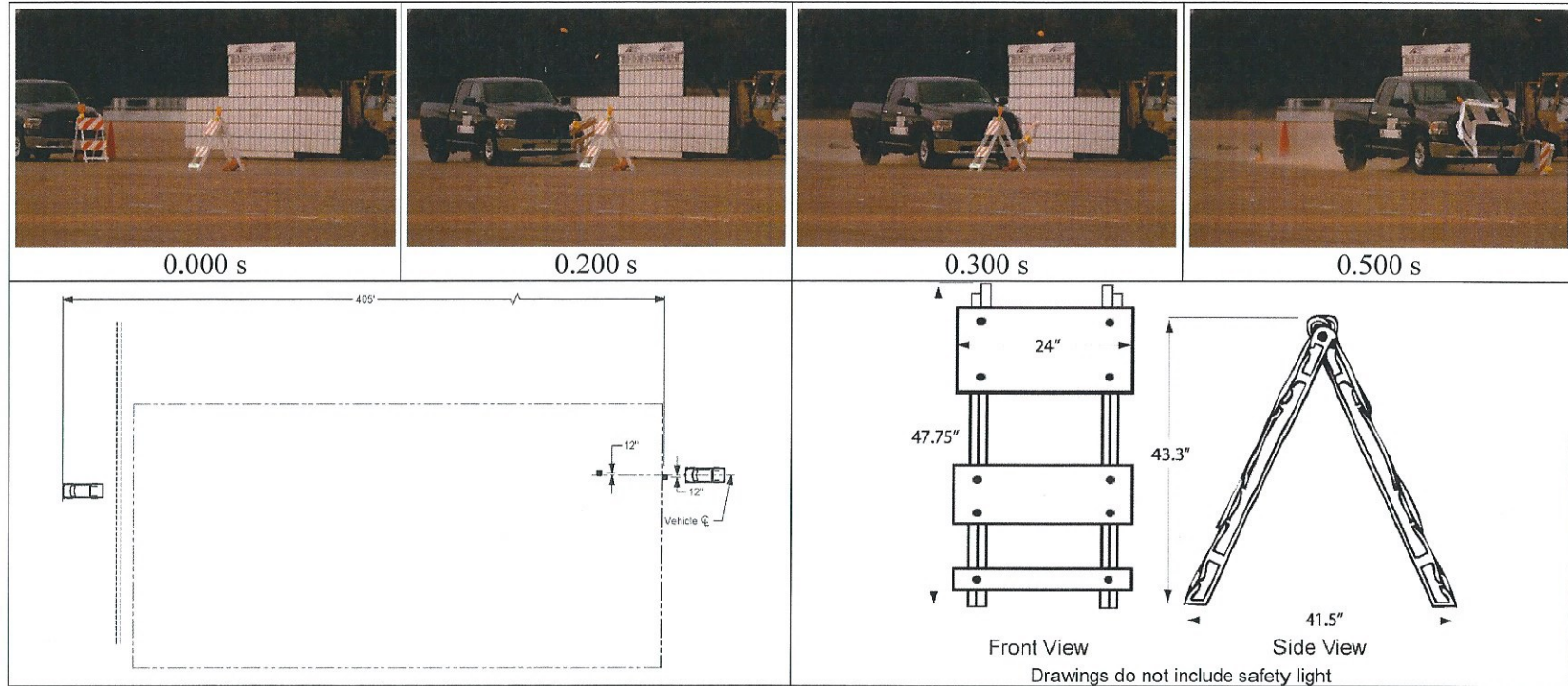

General Information

Test Agency..... Texas A&M Transportation Institute (TTI)
 Test Standard Test No..... MASH Test 3-72
 TTI Test No. 690900-PLP6
 Test Date..... 2019-10-28

Test Article

Type Work-Zone Traffic Control Device -
 Type I and Type II Barricade
 Name..... Plasticade® Fibercade®
 Installation Height/Weight .. 50.8 inches / 18 lb (both include light)
 Material or Key Elements ... HDPE legs, HDPE boards, safety light,
 and one 35-lb sand bag

Soil Type and Condition Concrete pavement, damp

Test Vehicle

Type/Designation..... 2270P
 Make and Model 2014 RAM 1500
 Curb..... 4977 lb
 Test Inertial..... 5062 lb
 Dummy No dummy
 Gross Static 5062 lb

Impact Conditions

Speed Barricade #1 62.1 mi/h
 Angle Barricade #1..... 0°
 Speed Barricade #2 61.7 mi/h
 Angle Barricade #2..... 90°
 Kinetic Energy #1 & #2..... 653 & 644 kip-ft

Exit Conditions

Speed Barricade #1 61.7 mi/h
 Speed Barricade #2 60.6 mi/h

Post-Impact Trajectory

Stopping Distance 405 ft downstream
 7 ft left

Maximum Test Debris Scatter

Barricade #1 and #2 240 ft downstream
 87 ft left/32 ft right

Vehicle Damage

VDS..... 12FD1
 CDC 12FDEW1
 Max. Exterior Deformation 0.75
 OCDI FS0000000
 Max. Occupant Compartment
 Deformation..... None
 Windshield Damage None

Figure 7.6. Summary of Results for MASH Test 3-72 at 0° and 90° on Plasticade® Fibercade® Type I and Type II Barricades.

FIBERCADE®

TYPE I & TYPE II BARRICADE

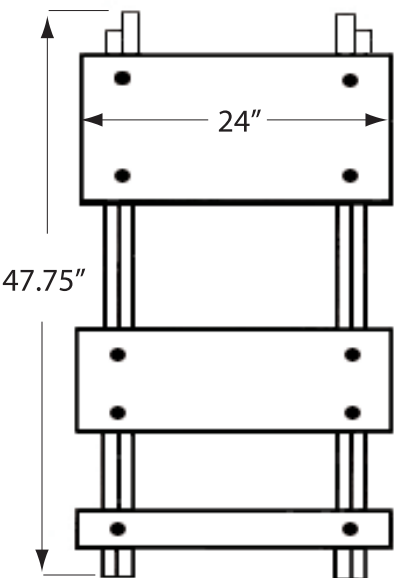

Front View

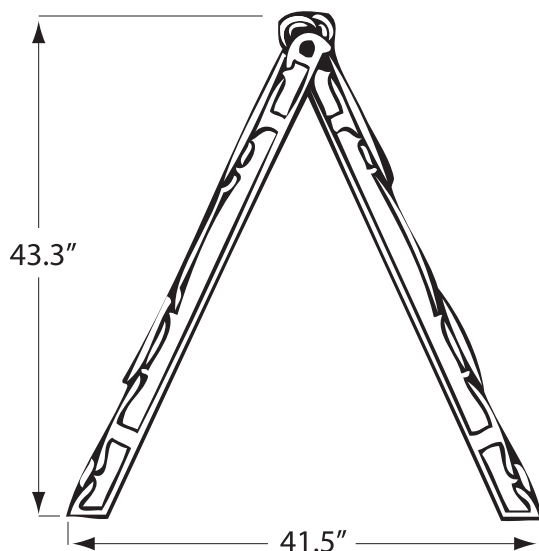

Side View

Specs

Composition	High Density Polyethylene
Dimensions	43.3"H x 24"W x 3"D
Colors	White
Weight	16 lbs.
Reflective Sheeting	Available in all grades in white and orange

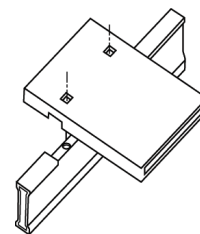

Holes are predrilled in the boards and legs for easy assembly when you purchase component parts



Purchase assembled with your choice of 12" x 24" or 8" x 24" top and bottom panels, with or without sheeting

PLASTICADE®

7700 N. Austin Avenue
Skokie, IL 60077
phone (800) 772-0355
fax (847) 966-8074

www.plasticade.com

Traffic Lane Closures, L.L.C.

Signs & Supplies for the M&P of Traffic
Certified W.B.E. / D.B.E.
www.trafficlane closures.com



Phone: 845-228-6100
Fax: 845-228-5450



1214 Route 52
Kent, NY 10512

MADE IN THE USA