

HEAVY DUTY DOUBLE SPRING SIGN STAND FOR RIGID SIGNS

**MASH
APPROVED**



Model SS420A

- Holds rigid signs 36" & 48"
- Automotive grade steel, double spring
 - designed to perform in extreme weather conditions without fatiguing or breaking
 - E-coated for maximum rust and corrosion resistance
- Telescoping mast
- Fixed length legs
 - lock in multiple positions to adjust to uneven ground
- Non-skid rubber feet
- Built-in three flag holder
- Replacement parts and assemblies available
- MASH Accepted for 48" - .080 aluminum signs, WZ-355
- Meets MUTCD Standards



Bracket for Rigid Sign
(patent pending)



Zinc Plated

Brackets for top and bottom of the sign have different clamp sizes to fit around telescoping mast.



Heavy Duty
Double Spring

PLASTICADE®

Plasticade.com

TF056 Rev. 4

HEAVY DUTY DOUBLE SPRING SIGN STAND FOR RIGID SIGNS

Specs

Material Model SS420A	Aluminum
Sign Mounting Height	18" from ground
Top of 48" Sign	86" H maximum
Carton Size	8.5" x 11.5" x 58.5"
Size Open legs collapsed footprint	legs don't collapse
Size Open legs fully extended footprint	38" x 81"
Weight	36 lbs.
Included Bracket	2 Rigid Sign Brackets

U.S. Patent 10,546,515

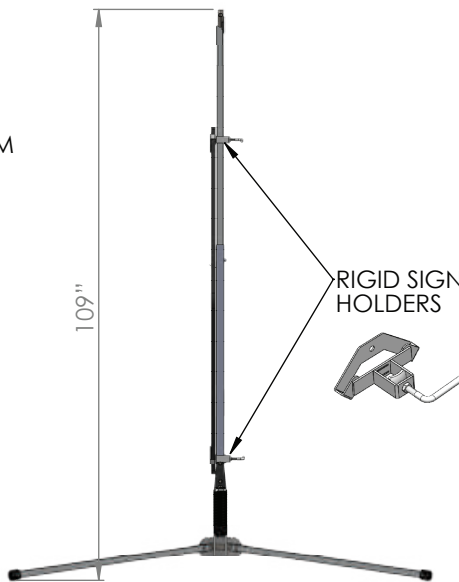
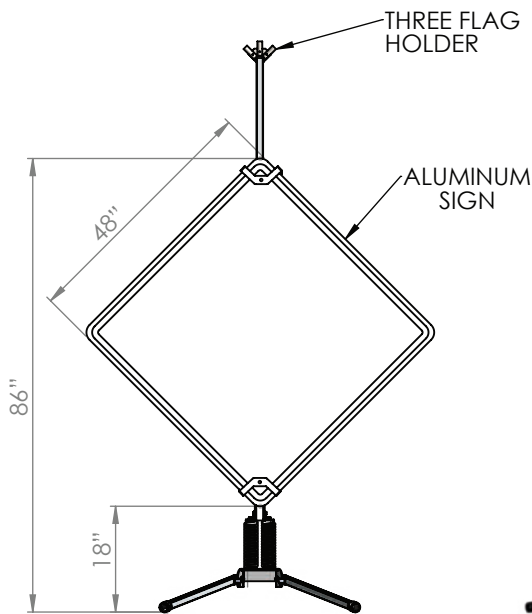
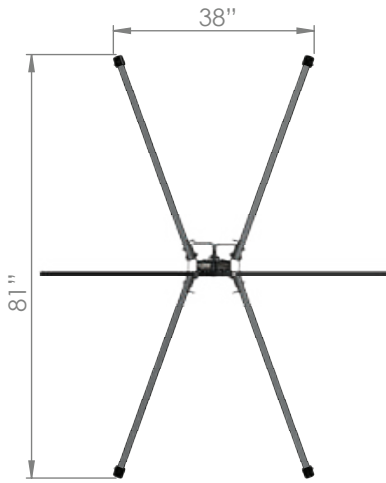

LEG RELEASE SYSTEM

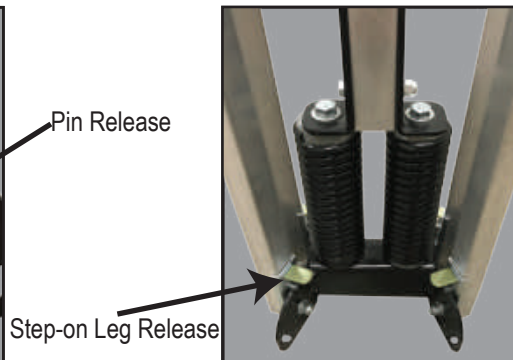
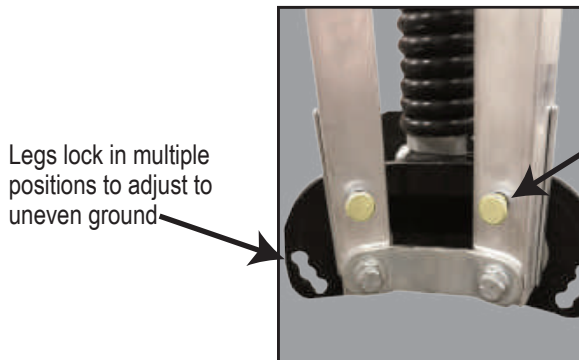

PLASTICADE®

100 Howard Avenue
Des Plaines, IL 60018
phone (800) 772-0355
fax (847) 966-8074

Plasticade.com